

Light Hex,
Grade 8

Nylon Insert (Elastic) Stop Nuts

Nuts

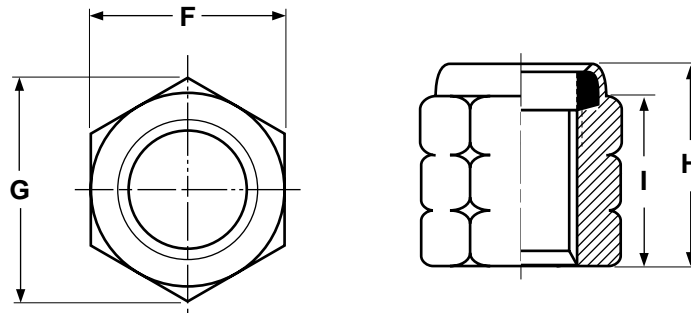

NYLON INSERT STOP NUTS, LIGHT HEX, GRADE 8								Esna®
Nominal Size or Basic Thread Diameter		F		H		I	G	
		Width Across Flats		Thickness		Side Height	Width Across Corners	
		Max	Min	Max	Min	Ref	Ref	
1/4	0.2500	.439	.430	.328	.298	.225	.482	
5/16	0.3125	.502	.492	.359	.329	.250	.552	
3/8	0.3750	.564	.553	.468	.438	.335	.622	
7/16	0.4375	.627	.616	.468	.438	.324	.694	
1/2	0.5000	.752	.741	.609	.579	.464	.837	
9/16	0.5625	.877	.865	.656	.626	.469	.978	
5/8	0.6250	.940	.928	.765	.735	.593	1.051	
3/4	0.7500	1.064	1.052	.890	.860	.742	1.191	
7/8	0.8750	1.252	1.239	.999	.969	.790	1.403	
1	1.0000	1.440	1.427	1.078	1.016	.825	1.615	
1-1/8	1.1250	1.627	1.614	1.203	1.141	.930	1.826	
1-1/4	1.2500	1.814	1.801	1.422	1.360	1.125	2.038	
1-3/8	1.3750	2.008	1.973	1.609	1.547	1.282	2.232	
1-1/2	1.5000	2.197	2.159	1.640	1.578	1.313	2.416	

Description	Heat treated hex nut with a nylon-filled collar at its back end. The nut shall be grade-marked in one of two ways: (1) with double notched corners or (2) with six symmetrically spaced identical symbols on the chamfered surface on top of the nut. When the cap-screw or bolt reaches the collar, the threads and nylon form a tight, frictional fit, restricting movement of the cap-screw or bolt when it is subjected to vibration. The nylon insert comes in various colors.
Applications/Advantages	Designed to be used in structural applications with Grade-8 cap-screws or bolts which have a minimum tensile strength of 150,000 psi. or greater. Some such applications include engines, turbines, hydraulic cylinders, railroads and aerospace. Nylon insert nuts are not designed to be used at temperatures over 250° F.
Material	Heat treated AISI C1137 or equivalent steel.
Hardness	Rockwell C 26 - 34
Proof Load	150,000 psi.
Plating	Grade-8 nylon insert stop nuts are usually supplied zinc yellow-plated. See Appendix-A for more information.

®Esna is a registered trademark of the MacLean-Fogg Company. Kanebridge's stop nuts are not manufactured by or connected with the producers of Esna® nuts.