

Self-Tapping Screws

METRIC

Trilobular Thread Rolling Screws

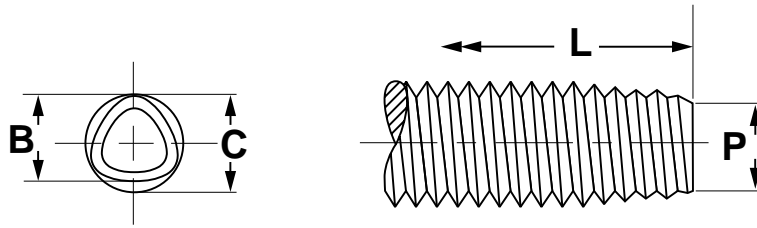

METRIC - TRILOBULAR THREAD ROLLING SCREWS										DIN 7500-1
Nominal Size & Thread Pitch	C		B		P	Test Plate Thickness	Hole Diameter	Minimum Braking Torque	Minimum Breaking Force	Maximum Rolling Torque
	Diameter of Circumscribing Circle		Major Thread Diameter		Point Diameter			Nm	N	Nm
	Max	Min	Max	Min	Max					
M2.5-0.45	2.55	2.47	2.48	2.38	2.11	2.5	2.3	1	2700	0.6
M3-0.5	3.05	2.97	2.95	2.87	2.57	3	2.75	1.5	4000	1
M4-0.7	4.07	3.99	3.93	3.85	3.39	4	3.6	3.4	7000	2.4
M5-0.8	5.08	5.00	4.92	4.84	4.30	5	4.6	7.1	11,400	4.7
Tolerance on Length			3-6mm: ± 0.375				6-10mm: ± 0.45			
			10-18mm: ± 0.55				18-30mm: ± 0.65			

Description	A trilobular thread forming screw with a machine screw's thread pitch. As each lobe of the screw moves through the pilot hole in the nut material, it forms and work hardens the nut thread metal, producing an uninterrupted grain flow.
Applications/ Advantages	For use in drilled, punched or cored holes in ductile metals and punch extruded metals. They provide superior prevailing torque than can be achieved with most locking screws. Eliminates chips that result from using thread cutting screws. Requires low drive torque and provides excellent resistance to vibrational loosening. Since these thread rolling screws are case hardened, it is not recommended they be used in die-cast or extruded aluminum or zinc.
Material	AISI 1022 Steel
Surface Hardness	550 HV 0.3 Min.
Case Depth	M2.5: 0.04-0.12 mm M3: 0.05-0.18 mm M4 & M5: 0.10-0.25 mm
Core Hardness	240 - 370 HV 5
Torsional Strength	The torque required to cause failure shall be equal to or greater than the breaking torque values shown in the above table.
Tensile Strength	The tensile force required to cause failure shall be equal to or greater than the breaking force values shown in the above table.
Plating	Thread rolling screws shall have a zinc finish with a wax coating. For more details see Appendix-A.

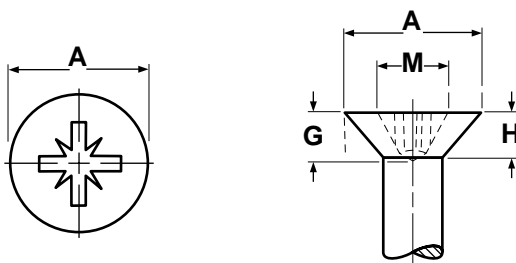

METRIC - TYPE Z (1A) FLAT HEADS FOR TAPPING SCREWS								DIN 965
Nominal Size	A		H		M	G		Drive Size
	Head Diameter		Head Height		Recess Diameter	Recess Penetration		
	Max	Min	Max	Ref	Max	Min		
M2.5	4.7	4.4	1.5	2.8	1.73	1.48	1	
M3	5.5	5.2	1.65	3	2.01	1.76	1	
M4	8.40	8.04	2.7	4.4	2.51	2.06	2	
M5	9.30	8.94	2.7	4.9	3.05	2.60	2	

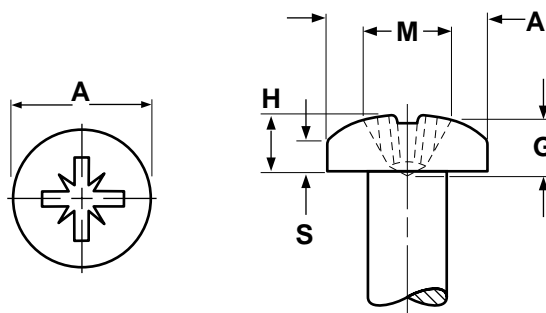

METRIC - TYPE Z (1A) PAN HEADS FOR TAPPING SCREWS									DIN 7985
Nominal Size	A		H		M	G		S	Drive Size
	Head Diameter		Head Height		Recess Diameter	Recess Penetration		Side Height	
	Max	Min	Max	Min	Ref	Max	Min	Ref	
M2.5	5.00	4.70	2.12	1.88	2.6	1.52	1.27	1.3	1
M3	6.00	5.70	2.52	2.28	3.0	1.93	1.68	1.6	1
M4	8.00	7.64	3.25	2.95	4.3	2.36	1.90	4.3	2
M5	10.00	9.64	3.95	3.65	5.0	3.10	2.64	2.5	2

Self-Tapping Screws

METRIC

Thread Rolling Screw Hole Size Data

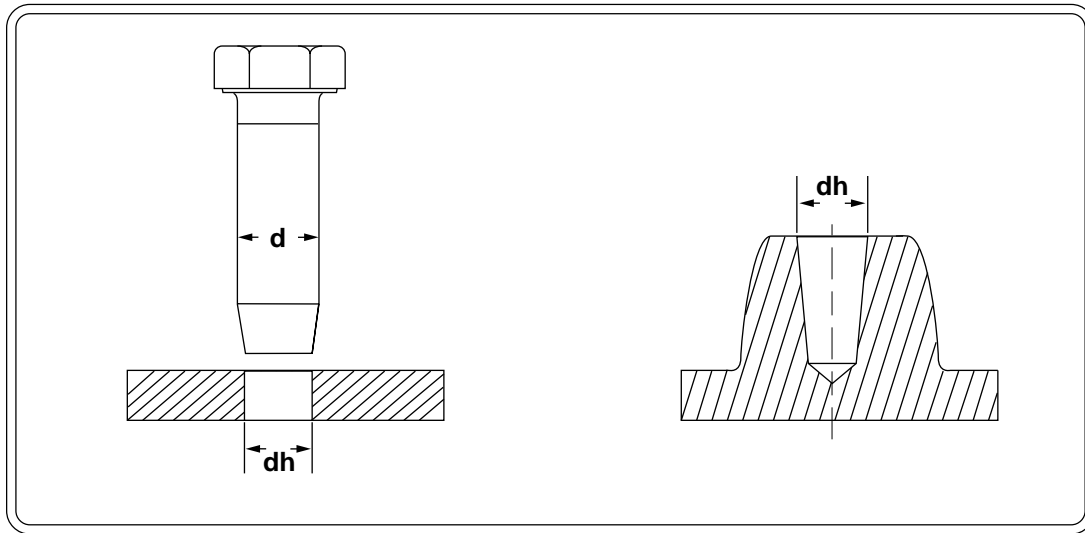

GUIDELINE VALUES FOR HOLE DIAMETERS USING DIN 7500 THREAD ROLLING SCREWS								DIN 7500
Thread Size	M2.5		M3		M4		M5	
Material thickness or length of engagement	Hole Diameter (dh)							
	Max	Min	Max	Min	Max	Min	Max	Min
0.8	2.31	2.25						
0.9	2.31	2.25						
1	2.31	2.25	2.76	2.7				
1.2	2.31	2.25	2.76	2.7				
1.5	2.31	2.25	2.76	2.7	3.66	3.6	4.56	4.5
1.6	2.31	2.25	2.76	2.7	3.66	3.6	4.56	4.5
1.7	2.31	2.25	2.76	2.7	3.66	3.6	4.56	4.5
1.8	2.31	2.25	2.81	2.75	3.66	3.6	4.56	4.5
2	2.31	2.25	2.81	2.75	3.66	3.6	4.56	4.5
2.2	2.31	2.25	2.81	2.75	3.66	3.6	4.56	4.5
2.5	2.31	2.25	2.81	2.75	3.71	3.65	4.56	4.5
3	2.36	2.3	2.81	2.75	3.71	3.65	4.56	4.5
3.2	2.375	2.3	2.825	2.75	3.725	3.65	4.625	4.55
3.5	2.375	2.3	2.825	2.75	3.725	3.65	4.625	4.55
4	2.375	2.3	2.825	2.75	3.725	3.65	4.625	4.55
5	2.375	2.3	2.825	2.75	3.775	3.7	4.675	4.6
5.5			2.825	2.75	3.775	3.7	4.675	4.6
6			2.825	2.75	3.775	3.7	4.675	4.6
6.3					3.79	3.7	4.74	4.65
6.5					3.79	3.7	4.74	4.65
7					3.79	3.7	4.74	4.65
7.5					3.79	3.7	4.74	4.65
8 thru 10							4.74	4.65

NOTES:

The values listed above are assigned to various materials and lengths of engagement and should be used as guidelines.