

Self-Tapping Screws *Thread Forming*

High-Low Style

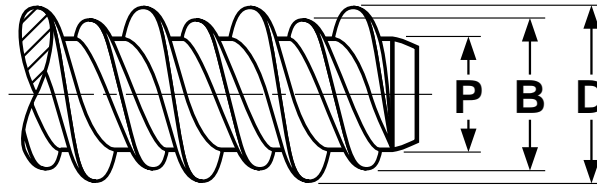

THREAD AND HOLE DIMENSIONS FOR HIGH-LOW THREAD FORMING SCREWS						Elco*, ANSI B18.6.4
Screw Size	D	B	P	Pilot Hole Diameter Flexural Modulus of Plastic		Minimum Torsional Strength, lb. in. (STEEL SCREWS ONLY)
	High Thread Diameter	Low Thread Diameter	Point Diameter	Up to 200,000 P.S.I.	200,000-400,000 P.S.I.	
2-32	.084 - .090	.069	.050 - .058	.0670	.0700	-
4-24	.105 - .115	.086	.061 - .070	.0810	.0860	4
5-20	.119 - .125	.100	.073 - .082	.0935	.0995	9
6-19	.135 - .145	.108	.080 - .090	.1015	.1100	13
7-19	.148 - .158	.130	.089 - .100	.1200	.1250	18
8-18	.160 - .170	.130	.095 - .105	.1200	.1285	18
10-16	.185 - .195	.145	.099 - .110	.1360	.1440	30
12-16	.210 - .220	.167	.125 - .137	.1570	.1660	39
1/4-15	.250 - .260	.200	.161 - .175	.1890	.2010	56
5/16-14	.307 - .317	.250	.200 - .212	.2380	.2500	142
Tolerance on Length			Up to 1 in., Incl.: +0, -3/64	Over 1 in.: +0, -1/16		

Description	A thread forming screw with a double-lead, consisting of a high and low thread. The lower thread varies in height from 1/3 to 1/2 that of the higher thread, which is sharper and flatter than a standard thread.
Applications/ Advantages	For use in plastic, nylon, wood or other low-density materials. Thread design reduces driving torques, enhances resistance to thread stripping, improves pullout strength and lessens risk of cracking the work piece.
Material	Steel: 1019-1022 or equivalent steel. Stainless: 410 martensitic or 18-8 austenitic stainless steel
Heat Treatment	Steel: Screws shall be quenched in liquid and then tempered by reheating to 650° F minimum. 410 Stainless: Screws shall be annealed by heating to 1850-1950° F, held at least 1/2 hour and rapid air- or oil-quenched then reheating to 525° F minimum for at least 1 hour and air cooled to provide the required tensile, yield and hardness properties.
Case Hardness	Steel: Rockwell C45 minimum
Case Depth (steel)	No. 2 thru 6 diameter: .002 - .007 No. 8 thru 12 diameter: .004 - .009 1/4" diameter and larger: .005 - .011
Core Hardness	Steel (after tempering): Rockwell C28 - 36 410 Stainless (after tempering): Rockwell C38 - 42 18-8 Stainless: Rockwell B100 (approximate)
Plating	See Appendix-A

*Elco is the original writer of high-low screw dimensions.

High-Low Style

Head Dimensions

Self-Tapping Screws

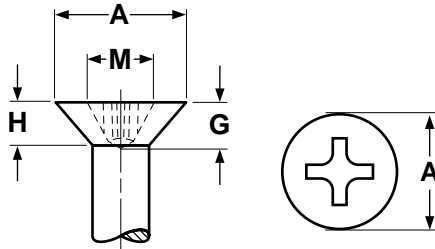

Nominal Size	A		H	M		G		Driver Size
	Head Diameter		Head Height	Recess Diameter		Recess Penetration Gaging Depth		
	Max	Min	Ref	Max	Min	Max	Min	
2	.162	.144	.051	.102	.089	.056	.040	1
4	.212	.191	.067	.128	.115	.082	.066	1
6	.262	.238	.083	.174	.161	.095	.072	2
8	.312	.285	.100	.189	.176	.110	.087	2
10	.362	.333	.116	.204	.191	.125	.102	2
12	.412	.380	.132	.268	.255	.139	.116	3
1/4	.477	.442	.153	.283	.270	.154	.131	3

Undercut Flat head High-Low screws conform to ASME B 18.6.4 specifications (see page 8).

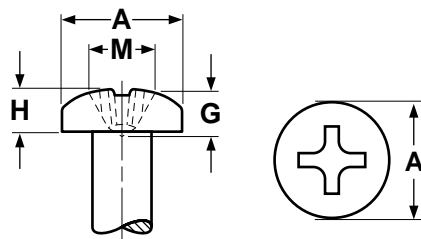

Nominal Size	A		H		M		G		Driver Size
	Head Diameter		Head Height		Recess Diameter		Recess Penetration Gaging Depth		
	Max	Min	Max	Min	Max	Min	Max	Min	
2	.167	.155	.062	.053	.104	.091	.052	.034	1
4	.193	.180	.071	.062	.112	.099	.061	.043	1
5	.219	.205	.080	.070	.122	.109	.071	.053	1
6	.254	.240	.097	.087	.158	.145	.072	.046	2
7 & 8	.270	.256	.097	.087	.166	.153	.080	.055	2
10	.322	.306	.115	.105	.182	.169	.097	.071	2
12	.373	.357	.133	.122	.199	.186	.113	.089	2
1/4	.492	.473	.175	.162	.281	.268	.144	.118	3

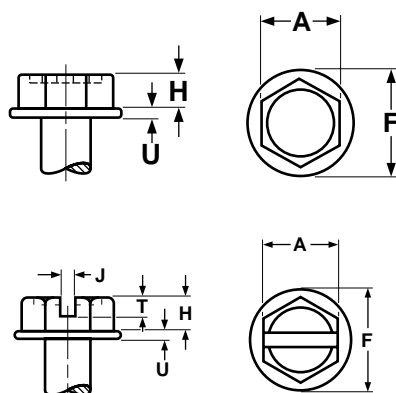

Nominal Size	A		T		J		H		F		U	
	Width Across Flats		Slot Depth		Slot Width		Height of Head		Diameter of Washer		Thickness of Washer	
	Max	Min	Max	Min	Max	Min	Max	Min	Max	Min	Max	Min
4	.125	.120	-	-	-	-	.055	.044	.177	.163	.016	.010
6	.187	.181	.049	.030	.043	.035	.070	.058	.260	.240	.025	.015
8	.250	.244	.053	.033	.048	.039	.093	.080	.328	.302	.025	.015
10	.250	.244	.074	.052	.054	.045	.110	.096	.348	.322	.031	.019
12	.312	.305	.103	.077	.067	.056	.155	.139	.432	.398	.039	.022
1/4	.375	.367	.111	.083	.075	.064	.190	.172	.520	.480	.050	.030
5/16	.375	.367	.111	.083	.075	.064	.190	.172	.520	.480	.050	.030

HEAD & DRIVE DIMENSIONS FOR SIX-LOBE PAN HIGH-LOW SCREWS								
Nominal Size	A		H		R	G	Fallaway Gauge Penetration	Driver Size
	Head Diameter		Head Height		Recess Diameter	Recess Gauge Penetration		
	Max	Min	Max	Min	Ref	Min	Max	
2	.167	.155	.062	.053	.094	.030	.019	T8
4	.193	.180	.071	.062	.094	.033	.019	T8
6	.254	.240	.097	.087	.111	.035	.022	T10
8	.270	.256	.097	.087	.132	.045	.026	T15
10	.322	.306	.115	.105	.155	.055	.031	T20
1/4	.492	.473	.175	.162	.221	.085	.044	T30

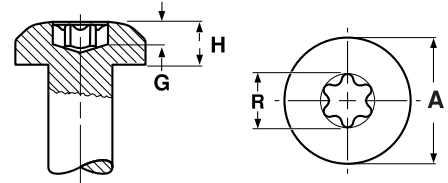

HEAD & DRIVE DIMENSIONS FOR TRUSS PHILLIPS HIGH-LOW									
Nominal Size	A		H		M	N	G		Driver Size
	Head Diameter		Head Height		Recess Diameter	Recess Width	Recess Penetration Gaging Depth		
	Max	Min	Max	Min	Ref	Ref	Max	Min	
4	.226	.211	.061	.051	.104	.018	.059	.042	1
6	.289	.272	.078	.066	.122	.019	.078	.060	1
8	.321	.303	.086	.074	.152	.027	.073	.048	2
10	.384	.364	.102	.088	.166	.029	.088	.063	2

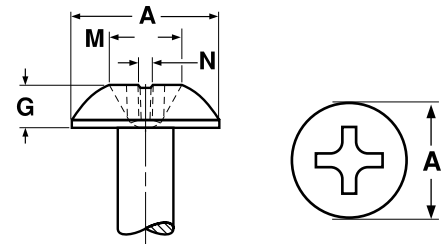

HEAD & DRIVE DIMENSIONS FOR TORX FLAT HIGH-LOW								
Nominal Size	A		H	M	G		Fallaway	Driver Size
	Head Diameter		Head Height	Recess Diameter	Recess Penetration Gaging Depth			
	Max	Min	Ref	Ref	Max	Min	Max	
2	.162	.144	.051	.069	.056	.040	.014	T6
4	.212	.191	.067	.094	.082	.066	.019	T8
6	.262	.238	.083	.111	.095	.072	.022	T10
8	.312	.285	.100	.132	.110	.087	.026	T15
10	.362	.333	.116	.155	.125	.102	.031	T20
1/4	.477	.442	.153	.200	.154	.131	.040	T27

