

# Oval

# Head Dimensions

# Self-Tapping Screws

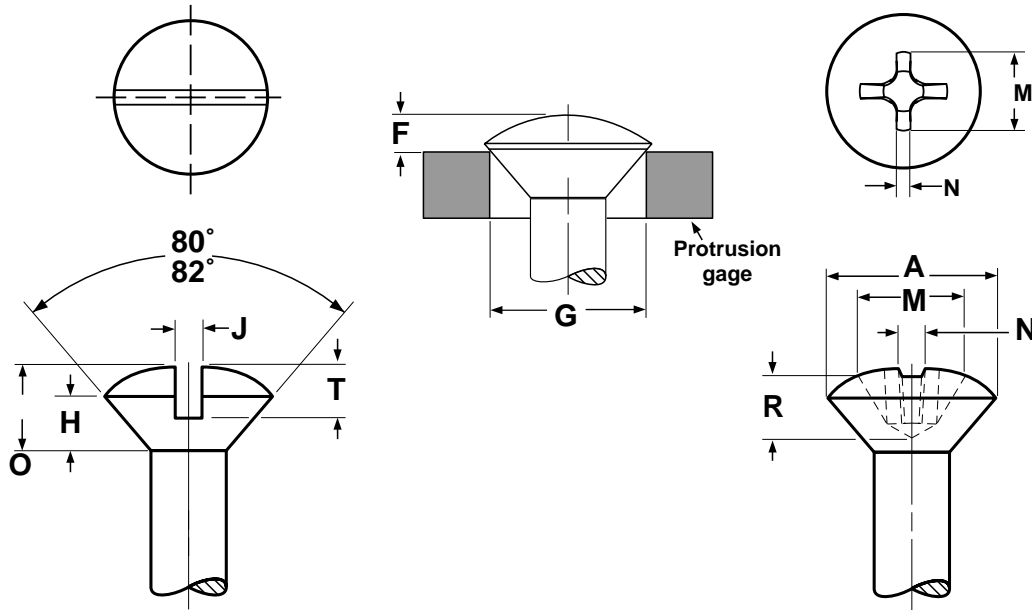

OVAL HEADS FOR SELF-TAPPING SCREWS														ANSI B18.6.4-1998			
Nominal Size	A		H		O		J		T		M	R	N	F		G	Phillips Driver Size
	Head Diameter		Height of Head		Width of Slot		Depth of Slot		Dimensions of Recess			Protrusion Above Gaging Diameter		Gaging Diam.			
	Max	Min	Max	Max	Max	Min	Max	Min	Ref	Ref	Ref	Min	Max				
0	.112	.096	.035	.056	.023	.016	.030	.025	.068	.036	.014	.047	.031	.078	0		
1	.137	.120	.043	.068	.026	.019	.038	.031	.070	.039	.015	.053	.035	.101	0		
2	.162	.144	.051	.080	.031	.023	.045	.037	.106	.060	.018	.058	.039	.124	1		
3	.187	.167	.059	.092	.035	.027	.052	.043	.118	.072	.019	.064	.044	.148	1		
4	.212	.191	.067	.104	.039	.031	.059	.049	.130	.086	.019	.069	.048	.172	1		
5	.237	.215	.075	.116	.043	.035	.067	.055	.152	.073	.028	.075	.053	.196	2		
6	.262	.238	.083	.128	.048	.039	.074	.060	.172	.092	.030	.080	.057	.220	2		
8	.312	.285	.100	.152	.054	.045	.088	.072	.186	.107	.031	.091	.066	.267	2		
10	.362	.333	.116	.176	.060	.050	.103	.084	.202	.125	.033	.102	.075	.313	2		
12	.412	.380	.132	.200	.067	.056	.117	.096	.264	.140	.038	.113	.084	.362	3		
14	.462	.427	.148	.224	.075	.064	.132	.108	.282	.152	.039	.125	.093	.410	3		
1/4	.477	.442	.153	.232	.075	.064	.136	.112	.284	.160	.040	.129	.095	.424	3		
5/16	.597	.556	.191	.290	.084	.072	.171	.141	.384	.226	.065	.155	.117	.539	4		
3/8	.717	.670	.230	.347	.094	.081	.206	.170	.404	.245	.068	.182	.139	.653	4		
7/16	.760	.715	.223	.345	.094	.081	.210	.174	.416	.257	.070	.195	.150	.690	4		
1/2	.815	.765	.223	.354	.106	.091	.216	.176	.430	.271	.071	.212	.163	.739	4		