

# Flat & Oval

# Head Dimensions

# Wood Screws

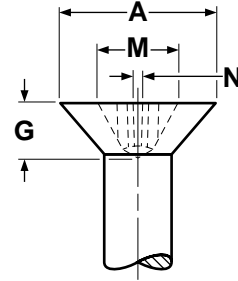
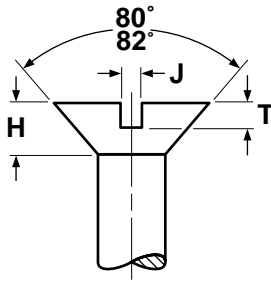

FLAT HEADS FOR WOOD SCREWS													ANSI B18.6.1
Nominal Size	A		H	J		T		M		G		N	Phillips Driver Size
	Head Diameter		Head Height	Width of Slot		Depth of Slot		Dimensions of Recess					
	Max	Min	Ref	Max	Min	Max	Min	Diameter		Depth		Width	
3	.199	.171	.059	.035	.027	.027	.017	.107	.094	.068	.052	.018	1
4	.225	.195	.067	.039	.031	.030	.020	.128	.115	.089	.073	.018	1
5	.252	.220	.075	.043	.035	.034	.022	.154	.141	.086	.063	.027	2
6	.279	.244	.083	.048	.039	.038	.024	.174	.161	.106	.083	.029	2
7	.305	.268	.091	.048	.039	.041	.027	.189	.176	.121	.098	.030	2
8	.332	.292	.100	.054	.045	.045	.029	.204	.191	.136	.113	.032	2
9	.358	.316	.108	.054	.045	.049	.032	.214	.201	.146	.123	.033	2
10	.385	.340	.116	.060	.050	.053	.034	.258	.245	.146	.123	.034	3
12	.438	.389	.132	.067	.056	.060	.039	.283	.270	.171	.148	.036	3
14	.507	.452	.153	.075	.064	.070	.046	.283	.270	.171	.148	.036	3

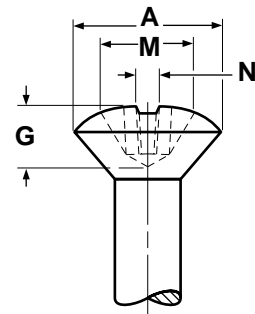
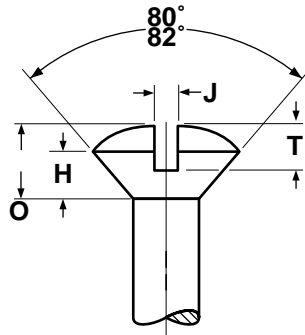

OVAL HEADS FOR WOOD SCREWS														ANSI B18.6.1	
Nominal Size	A		H	O		J		T		M		G		N	Phillips Driver Size
	Head Diameter		Height of Head		Width of Slot		Depth of Slot		Dimensions of Recess						
	Max	Min	Side Height	Total Height	Max	Min	Max	Min	Diameter		Depth		Width		
4	.225	.195	.067	.104	.084	.039	.031	.059	.049	.136	.123	.094	.077	.019	1
5	.252	.220	.075	.116	.095	.043	.035	.067	.055	.158	.145	.085	.061	.028	2
6	.279	.244	.083	.128	.105	.048	.039	.074	.060	.178	.165	.105	.080	.030	2
8	.332	.292	.100	.152	.126	.054	.045	.088	.072	.205	.192	.131	.106	.033	2
9	.358	.316	.108	.164	.137	.054	.045	.095	.078	.216	.203	.144	.119	.034	2
10	.385	.340	.116	.176	.148	.060	.050	.103	.084	.261	.248	.142	.118	.037	3